



Installation Manual

**Air Exchanger
CW-BOREAS-2252**

Manual Version 1.0

Contents

1.0	Safety Standards.....	3
1.1	Safety Information	3
2.0	Scope of supply	4
3.0	Preparation of cabinet	6
4.0	Set position of climate module	7
5.0	Preparation of roof module	8
6.0	Mounting.....	9
6.1	Remove lid of cabinet.	9
6.2	Remove plastic fixing screws.....	9
6.3	Remove metal blanking plate.....	10
6.4	Install metal profile bar.	10
6.5	Insert air exchanger.....	11
6.6	Secure air exchanger.	11
6.7	Secure metal planking plate.....	12
6.8	Ground the air exchanger.....	12
6.9	Connect cabling and re-install the roof.....	12
7.0	Maintenance	13
8.0	Troubleshooting guide	14
9.0	Additional Information.....	15
10.0	Manufacturer’s Warranty.....	16

Version	Date	Description	Author
CW2252.1	19.05.2023	Initial issue for peer review	
CW2252.2	24.07.2023	Amendments following peer review	
CW2252.3	26.07.2023	Ready for circulation	

1.0 Safety Standards

1.1 Safety Information

- This device can only be serviced by qualified experts.
- Disconnect the fans before starting maintenance.
- Cut off the air exchanger from the power supply completely (see data sheet).
- Protect from rain or water.
- Connect only with marked power sources – follow instructions.
- Make sure no foreign objects or liquids get into the housing.

Observe the relevant regulations. This instruction manual contains information to enable the user to work safely and correctly. Only when the manual is understood and adhered to can danger be avoided.

2.0 Scope of supply

The air exchanger system is provided with the following components and accessories, which are included as part of the scope of supply:

Model: [BOREAS-2252]

Description:

The air exchanger unit is a critical component of the ventilation system that helps regulate temperature and maintain optimal conditions within the cabinet. It plays a crucial role in dissipating heat generated by electronic equipment and ensuring the reliable operation of communication devices.

Specifications:

PWR 48VDC max 6A, Aux Output 48VDC max 2A, Fan Speed 2600 ± 200 rpm, Max Air Flow 1005 m³/h, Acoustic noise 69 db. dimensions, etc.

Filters:

1 x Tri-Foam Hydrophobic Mesh
2x Small Hydrophobic Mesh

Control Panel:

The control panel supports up to 4 fans with only 2 used in this model.

The control panel allows configuration of fan curves using the TMS program and supplied OPTO cable. Cherry & White should be consulted on optimal fan curves.

Installation Accessories:

The unit is supplied with 1 profile bar and 1 blanking plate. The fixing points can be reused from the existing panel.

Please note that the scope of supply may vary depending on the specific model and package selected. Refer to the product documentation provided with your air exchanger system for detailed information on the exact components and accessories included in your package.

It is important to carefully inspect the delivered items upon receipt to ensure that all components mentioned in the scope of supply are present and in good condition. If any items are missing or damaged, please contact our customer support immediately to resolve the issue.

Proper installation and operation of the air exchanger system, in accordance with the provided manuals and guidelines, will ensure optimal performance and longevity of the equipment. Refer to the respective installation and operation sections of this manual for detailed instructions on how to install, operate, and maintain your air exchanger system.

Air exchanger layout:

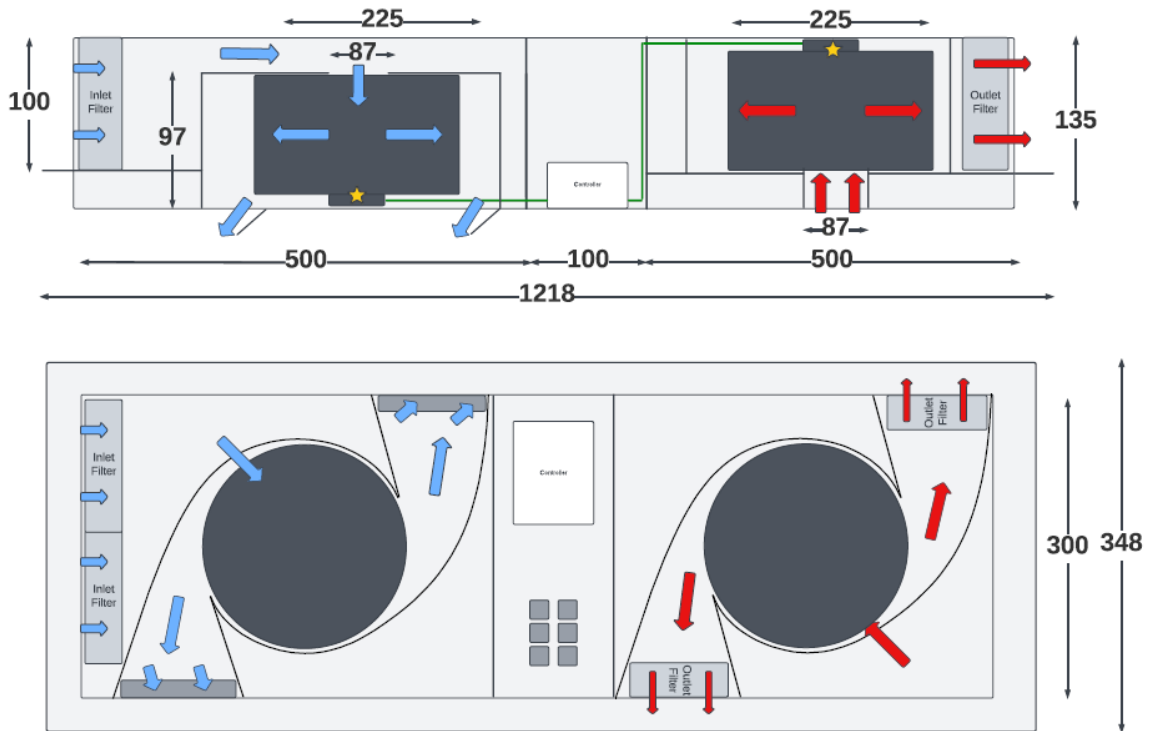

Port Layout:

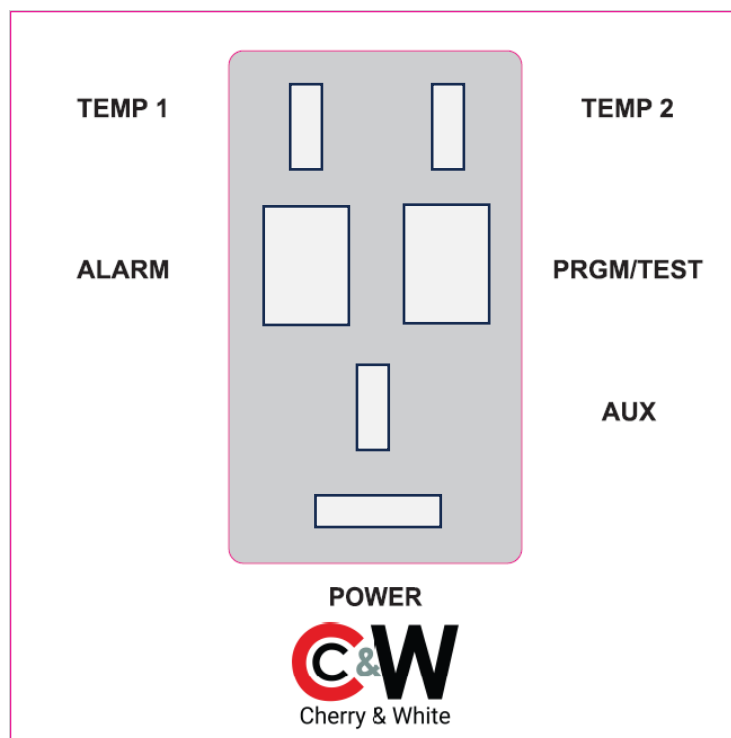

3.0 Preparation of cabinet

Before installing the air exchanger system, it is important to ensure that the cabinet or designated installation location meets the necessary requirements for proper installation and operation. Follow the guidelines below to prepare the cabinet:

Clear the Area:

Remove any objects or obstacles from the designated installation area to provide sufficient space for the air exchanger system. Ensure that there is ample clearance around the cabinet for proper airflow and maintenance access.

Check the Structural Integrity:

Verify that the cabinet or wall structure is strong and stable enough to support the weight of the air exchanger system. Ensure that the cabinet is free from any structural damage or defects that may compromise its integrity.

Electrical Connections:

Ensure that an appropriate power supply is available near the installation location. Consult the electrical requirements specified in the air exchanger system's documentation and ensure that the power supply meets these requirements. If necessary, consult a qualified electrician to install or modify the electrical connections.

Ventilation:

Ensure that there is adequate ventilation in the installation area to facilitate the intake and exhaust airflow of the air exchanger system. Verify that there are no obstructions or blockages that may impede the flow of air. Consider the positioning of the cabinet in relation to other objects or walls to allow for proper airflow.

Mounting Surface:

If required, prepare the mounting surface to accommodate the installation of the air exchanger system. Ensure that the surface is clean, level, and suitable for securely mounting the system. Follow the recommended guidelines provided in the installation manual regarding the specific mounting requirements for your air exchanger model.

Noise and Vibration:

Consider the noise and vibration produced by the air exchanger system during operation. If necessary, take measures to minimize the impact of noise and vibration on occupants or adjacent areas, such as installing vibration isolation pads or utilizing soundproofing materials. It is crucial to adhere to all safety regulations and local building codes during the preparation of the cabinet. Failure to do so may result in improper installation, reduced performance, or potential safety hazards. Consult the complete installation manual and any additional documentation provided with your air exchanger system for detailed instructions specific to your model.

4.0 Set position of climate module

The proper positioning of the climate module is crucial for the efficient operation and performance of the air exchanger system. Follow the guidelines below to correctly set the position of the climate module:

Location Selection:

Choose a suitable location for the climate module that allows for easy access during installation, operation, and maintenance. Consider placing the module in an area that is convenient for connecting the necessary ductwork and electrical connections.

Mounting Surface:

Ensure that the mounting surface is sturdy, level, and capable of supporting the weight of the climate module. Verify that the surface is clean and free from any debris or obstructions that may hinder proper installation.

Accessibility:

Allow adequate space around the climate module for servicing, filter replacement, and routine maintenance. Ensure that there is enough clearance to remove and replace the filters without any difficulty.

Ventilation:

Provide proper ventilation around the climate module to facilitate the intake and discharge of air. Avoid placing the module in areas with restricted airflow, such as tight corners or enclosed spaces.

Clearance from Obstructions:

Ensure that there is sufficient clearance around the climate module to avoid obstructions that may hinder the air intake or exhaust. Keep the module away from walls, furniture, or other objects that could impede the airflow.

Electrical Connections:

Position the climate module in proximity to the necessary electrical connections while ensuring compliance with local electrical codes. Consult the provided electrical requirements and connect the module to a suitable power supply.

Secure Mounting:

Follow the manufacturer's instructions to securely mount the climate module on the designated mounting surface. Utilise the recommended brackets, screws, or other mounting hardware to ensure a stable and vibration-free installation.

Properly setting the position of the climate module is essential for the efficient functioning of the air exchanger system. Refer to the complete installation manual and any additional documentation provided by the manufacturer for specific instructions related to your air exchanger model. Adhere to all safety regulations and local building codes during the installation process to ensure optimal performance and safe operation of the system.

5.0 Preparation of roof module

Installing the air exchanger into the roof mount of a cabinet requires proper preparation to ensure a successful installation and efficient operation. Follow the guidelines below for installing the roof module:

Roof Inspection:

Thoroughly inspect the roof of the cabinet to ensure it is structurally sound and capable of supporting the weight of the module. Check for any damage. Repair/report any issues before proceeding with the installation.

Structural Support:

Securely support and anchor the roof module to the roof structure. Use the provided mounting brackets or frames to provide stability and prevent movement or damage caused by external forces.

Electrical Connections:

Determine the electrical requirements for the roof module and ensure a suitable power supply is available at the installation site. Consult the provided electrical specifications and connect the module to the designated power source, following safety guidelines and local electrical regulations.

Safety Measures:

Adhere to appropriate safety precautions during the installation, including the use of personal protective equipment (PPE) and adherence to safe work practices. Secure the work area to prevent unauthorised access and minimize the risk of accidental falls.

Proper preparation of the roof module is crucial for the successful installation and long-term performance of the air exchanger system. Refer to this installation manual and any additional documentation provided by the manufacturer for specific instructions related to your air exchanger model. Always comply with safety regulations and local building regulations to ensure optimal performance and safe operation of the system.

6.0 Mounting

Proper mounting of the air exchanger is essential to ensure stability, functionality, and safe operation. Follow the steps outlined below for the installation of the climate module, filler plate, and grounding:

6.1 Remove lid of cabinet.

Remove the 2 securing rods located on the left and right of the cabinet behind the door hinges. If they cannot be removed by hand you may need to use a set of plyers/mole grips to rotate them as you pull. Then lift the complete roof off the cabinet.

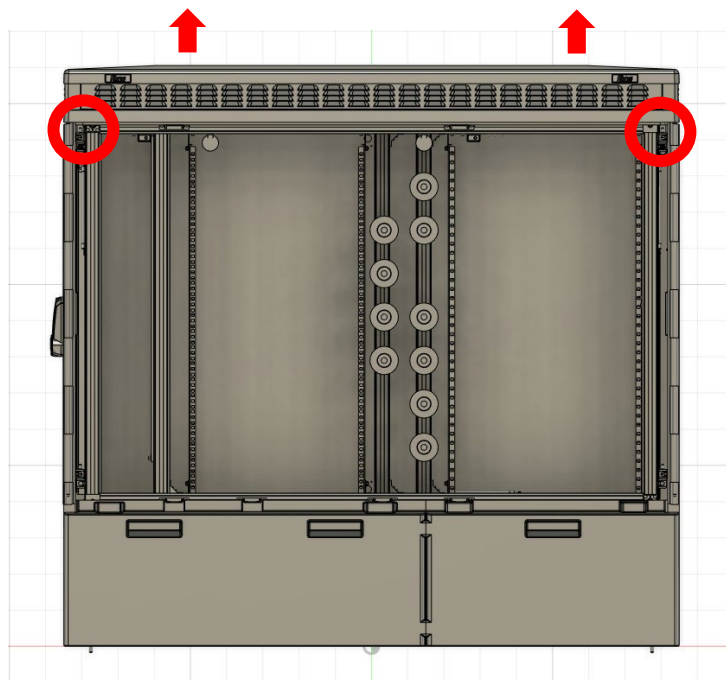

6.2 Remove plastic fixing screws.

Remove the quarter turn plastic fixing screws from the top of the cabinet. Keep these for later as they will need to be used when securing the air exchanger.

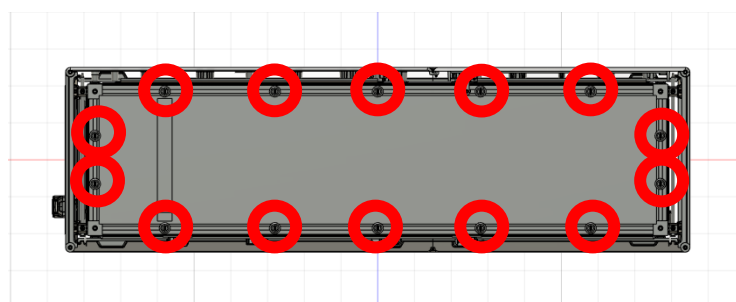

6.3 Remove metal blanking plate.

Remove the large metal blanking plate and store this in a safe place.

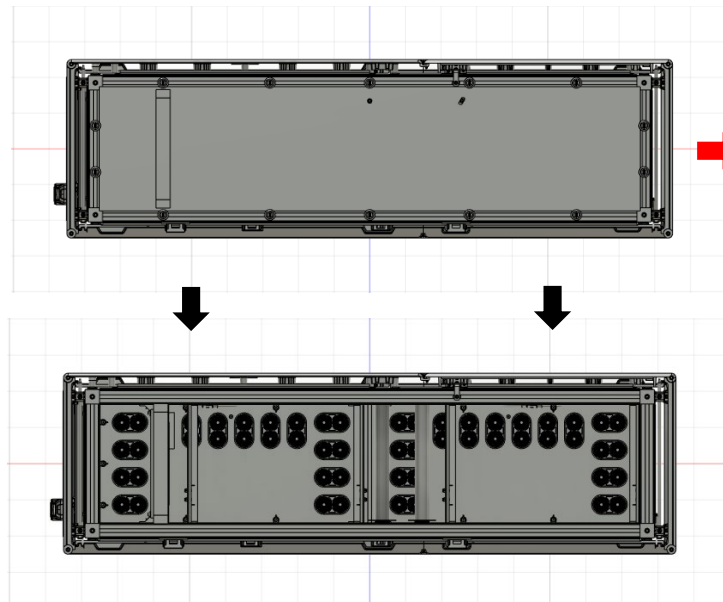

6.4 Install metal profile bar.

If you are installing into a SiCab 15 or above position the metal profile bar 124 cm away from the right-hand top profile bar and secure with an m6 bit.

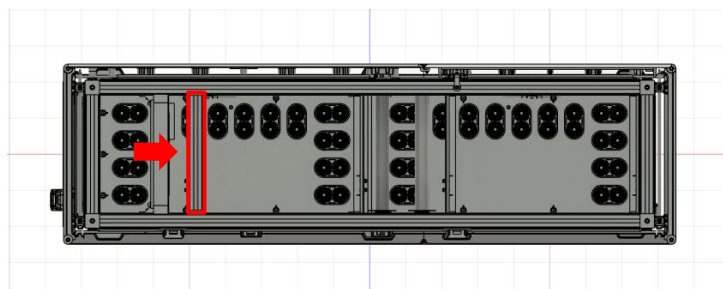

6.5 Insert air exchanger.

Lower the air exchanger into position aligning the outer rim with the inside edge of the profile bars. It should sit centrally and not overlap on any sides into the bars void.

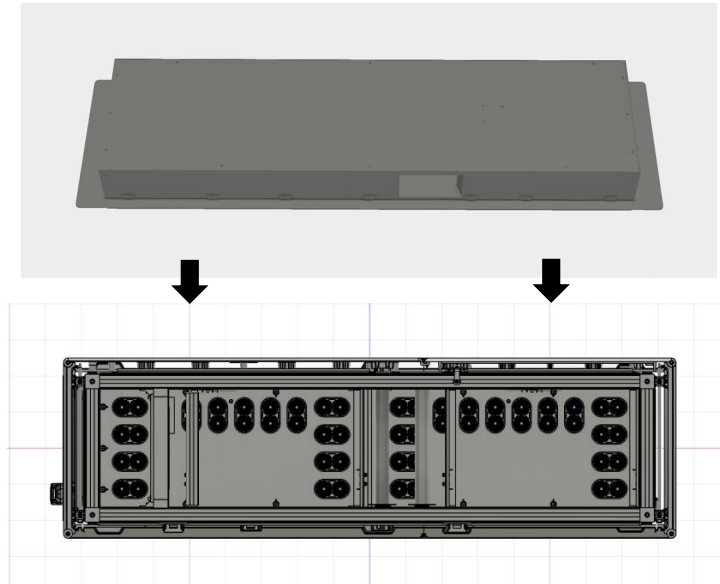

6.6 Secure air exchanger.

Secure the air exchanger using the plastic fixings screws you previously removed. You may need to adjust the spacing of these as appropriate.

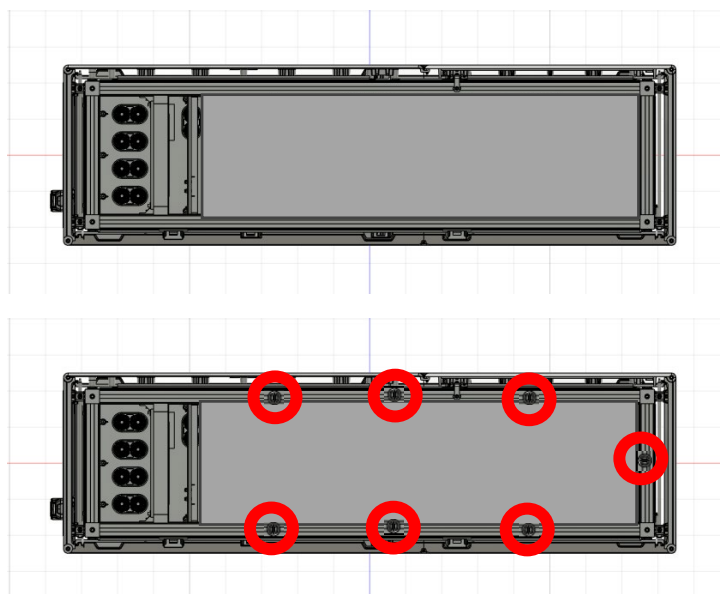

6.7 Secure metal planking plate.

Secure the metal blanking plate using the remaining plastic fixing screws you previously removed.

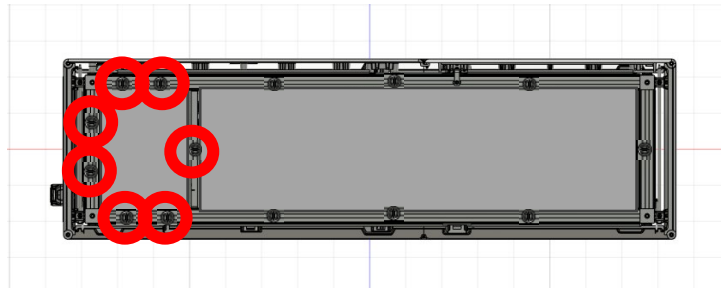

6.8 Ground the air exchanger.

Secure the grounding cable coming off the lower side of the air handler to a profile bar located in vicinity to the air exchanger. This can be secured using a m6 bit.



6.9 Connect cabling and re-install the roof.

Connect the cabling as per the port diagram below. Then reinstall the roof and securing bars.

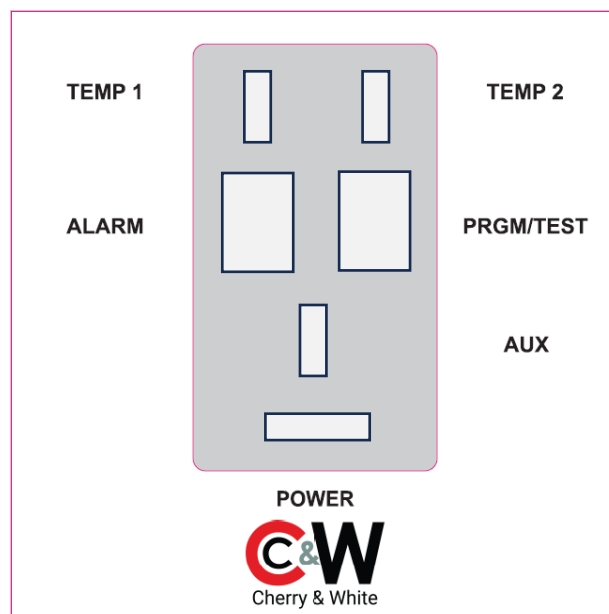

Temperature 1 should always be prioritised as this is the primary input.

Auxiliary power input cables and TMS programming cables can be purchased upon request.

7.0 Maintenance

Filters should be checked at least every 12 months for debris.

The Tri-Foam Hydrophobic Mesh filter (CW-230419-1) can be cleaned using a compressed air canister by a technician. If excess buildup of debris is still present the filter should be replaced.

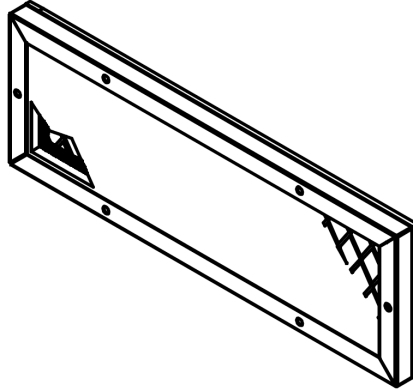

The Small Hydrophobic Mesh filter (CW-230419-2) can be cleaned with a compressed air canister by a technician indefinitely.

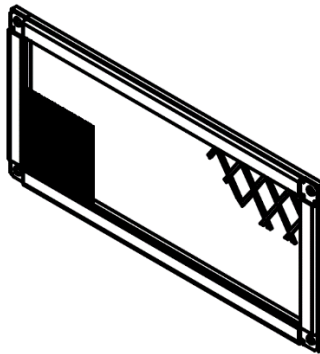

Caution should be used on both filters to ensure the sealing panel on the rear of the filter is not damaged. In the case of damage, the filter should be replaced immediately.



Disconnect the power cable before servicing the unit.



Do not operate the system without filters installed.

8.0 Troubleshooting guide

Problem	Possible Reasons	Troubleshooting
Fan does not start	No power supply	Make sure the power supply line is connected correctly, otherwise troubleshoot a connection error.
Low air flow	Filters, fans or the	Clean or replace the filters, clean the fans
	The ventilation system is soiled or damaged	Make sure the air ducts are clean and intact
	Incorrect Fan Curve	Check the fan curve programmed on the device.
	Temperature Cable	Check that the temperature cable is not damaged and is correctly inserted to the port.
Noise, vibration	The fan impeller is soiled	Check the impellers
	Fan screw connection is loose	Check tightening torques
Static Buildup	No ground connected	Check the ground connection

9.0 Additional Information



Roof Modules with two row ventilation openings must be replaced.



Power should only be connected once appropriate grounding has been established.



The air exchanger is designed as such to be serviceable without disassembly. Unsealing the unit will result in the warranty being voided.



Do not store the air exchanger on a flat surface in an upright position as this may lead to port damage.



This product is only suitable for use with the Sichert SiCab 12, 15, 18 and 24



If cables appear damaged do not use and contact Cherry & White.



Fan curves should only be adjusted by trained engineers as improper configuration could lead to damage.

10.0 Manufacturer's Warranty



WARRANTY CERTIFICATE

Please complete the following details and retain with the original purchase receipt

Owner's name:

Address:

County: Postcode:

Model No: Serial No:

Date of Purchase: / / Invoice No:

Installer's Name: Installer's Telephone No:

Installation date: / /

Cherry & White Ltd, 12 Olympus Park, Quedgeley, Gloucester, GL2 4NF
T +44 1452 764 701
E enquiries@cherry-white.co.uk
W www.cherry-white.co.uk

Manufacturer's Warranty

This product is compliant with EU norms and standards on low voltage guidelines and electromagnetic compatibility. We hereby declare that the product complies with the provisions of Electromagnetic Compatibility (EMC) directive.

The manufacturer hereby warrants normal operation of the unit for 12 months after the retail sale date provided the user's observance of the transportation, storage, installation, and operation regulations. Should any malfunctions occur during the unit operation through the manufacturer's fault, during the guaranteed period of operation, the user is entitled to get all the faults eliminated by the manufacturer by means of warranty repair at the factory free of charge. The warranty repair includes work specific to elimination of the faults in the unit operation, to ensure its intended use by the user within the guaranteed period of operation. The faults are eliminated by means of replacement or repair of the unit components or a specific part of such unit component.

To benefit from warranty repair, the user must provide the unit, the warranty certificate with the purchase date stamp, and the payment paperwork certifying the purchase. The unit model must comply with the one stated in the warranty certificate. Contact the seller for warranty service.

The Warranty repair does not include:

- Routine technical maintenance.
- Unit installation/dismantling
- Unit setup

The manufacturer's warranty does not apply to the following cases:

- User's failure to submit the unit with the entire delivery package as stated in the user's manual including submission with missing component parts previously dismantled by the user.
- Mismatch of the unit model and the brand name with the information stated on the unit packaging and in the user's manual.
- User's failure to ensure timely technical maintenance of the unit.
- Replacement and use of any assemblies' parts and components not approved by the manufacturer.
- Unit misuse.
- Violation of the unit installation regulations by the user.
- Violation of the unit control regulations by the user.
- Unit connection to mains power with a voltage different from the one stated in the user's manual.
- Unit breakdown due to voltage surges in mains power.
- Discretionary repair of the unit by the user.
- Unit repair by any persons without the manufacturer's authorization.
- Expiration of the unit warranty period
- Violation of the unit transportation regulations by the user.
- Violation of the unit storage regulations by the user
- Wrongful actions against the unit committed by third parties
- Unit breakdown due to circumstances of insuperable force (fire, flood, earthquake, war, hostilities of any kind, blockades).
- Missing seals if provided by the user's manual.
- Failure to submit the user's manual with the unit purchase date stamp.
- Missing payment paperwork certifying the unit purchase.



Following the regulations stipulated herein will ensure a long and trouble-free operation of the unit



User's warranty claims shall be subject to review only upon presentation of the unit, the payment document and the user's manual with the purchase date stamp.